

# Balancing valve STV 65-150



## Areas of use

The balancing valve STV is used to adjust and balance the flow in heating and cooling systems. Examples of usage areas include mains, paths, branch lines, shunt groups and cooling baffles.

## Description

STV is a flanged valve without a drain. The valve is equipped with self-sealing measuring sockets, placed at a 45° angle in relation to the wheel centre. The handwheel is equipped with a digital display. The valve is set at the desired flow or kv-value according to the diagram by means of the wheel. When the value of the valve is set, it can be locked. This is done by screwing down the inner spindle to its end position with a 6 mm Allen key. After locking, the valve can be closed but can not however be opened to a higher kv value than the one set. The handwheel can be sealed according to the figure.

To avoid turbulence which can affect the measuring accuracy the valve should not be assembled close to bends, branch lines and other valves directly before or after the valve according to the figure.

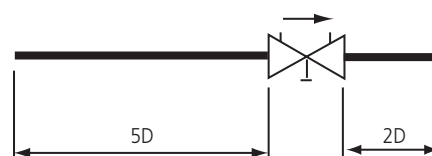
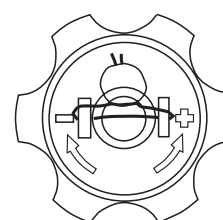

## Technical data

### Pressure class

PN 16

### Max temperature

120°C

### Min temperature

-20°C

### Max closing pressure

200 kPa

### Min pressuredrop

5 kPa

### Recommended pressure drop at rated valve

5-10 kPa

### Material

Cast iron

Gaskets EPDM

## Dimensions

	Dim	A	B	Weight /kg
DN 65	65	290	225	14
DN 80	80	310	240	20
DN 100	100	350	260	26
DN 125	125	400	290	40
DN 150	150	480	300	50

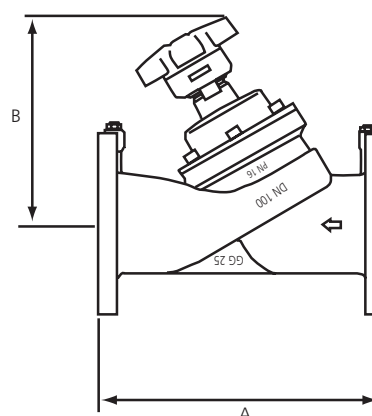

## Setting

By means of the wheel, the valve is set at the desired flow or kv-value according to the diagram. When the value of the valve is set, it is locked. This is done by screwing down the inner spindle to its end position with a 6 mm Allen key. After locking, the valve can still be closed but cannot however be opened at a higher kv value than the one set.

## kv-value

No turns	DN65	DN80	DN100	DN125	DN150
1	2,8	5,5	8,0	10,0	18,0
2	5,1	9,5	13,5	22,0	33,0
3	9,6	13,5	19,0	33,0	68,0
4	20,0	18,5	33,0	63,0	130,0
5	35,5	29,5	67,0	106,0	186,0
6	51,0	49,0	99,5	150,0	246,0
7	66,0	68,5	125,0	194,0	294,0
8	78,5	85,0	150,0	236,0	340,0
9	87,0	98,0	170,0	273,0	385,0
10	93,5	110,0	190,0	301,0	425,0

## Flow measuring

The measuring instrument is connected to the measuring socket of the valve. The instrument is pre-programmed with the characteristics of all our adjustment valves and proving rings.

Other valve manufacturers' data is also added to the instrument. Values for pressure drop and flow can be read directly on the display.

If you do not have access to the MMA instrument some other brands can be used. The flow can then be read from the pressure drop diagram found in the operating instructions.

### Accuracy

Accuracy is greatest when the valve is fully open. The smaller the opening, the importance of manufacturing tolerances increases, as variations in measurements are then greater percentage-wise. It is better to choose a valve that has a pre-set value above three turns.

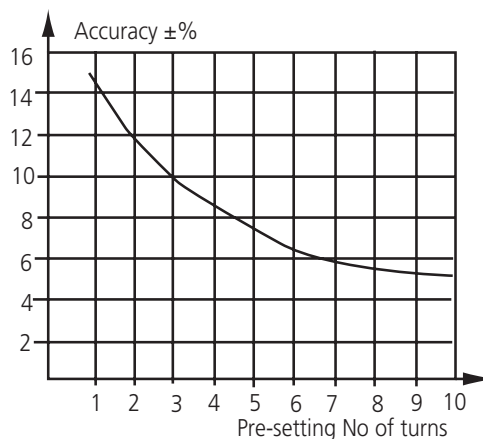

## Ordering codes

RSK no.	Art.no.	Name	Description
489 25 65	2250702	STV 65	Balancingvalve flanged without drain
489 25 66	2250802	STV 80	Balancingvalve flanged without drain
489 25 67	2250902	STV 100	Balancingvalve flanged without drain
489 25 68	2251002	STV 125	Balancingvalve flanged without drain
489 25 69	2251102	STV 150	Balancingvalve flanged without drain

We reserve the right to alter information without notice

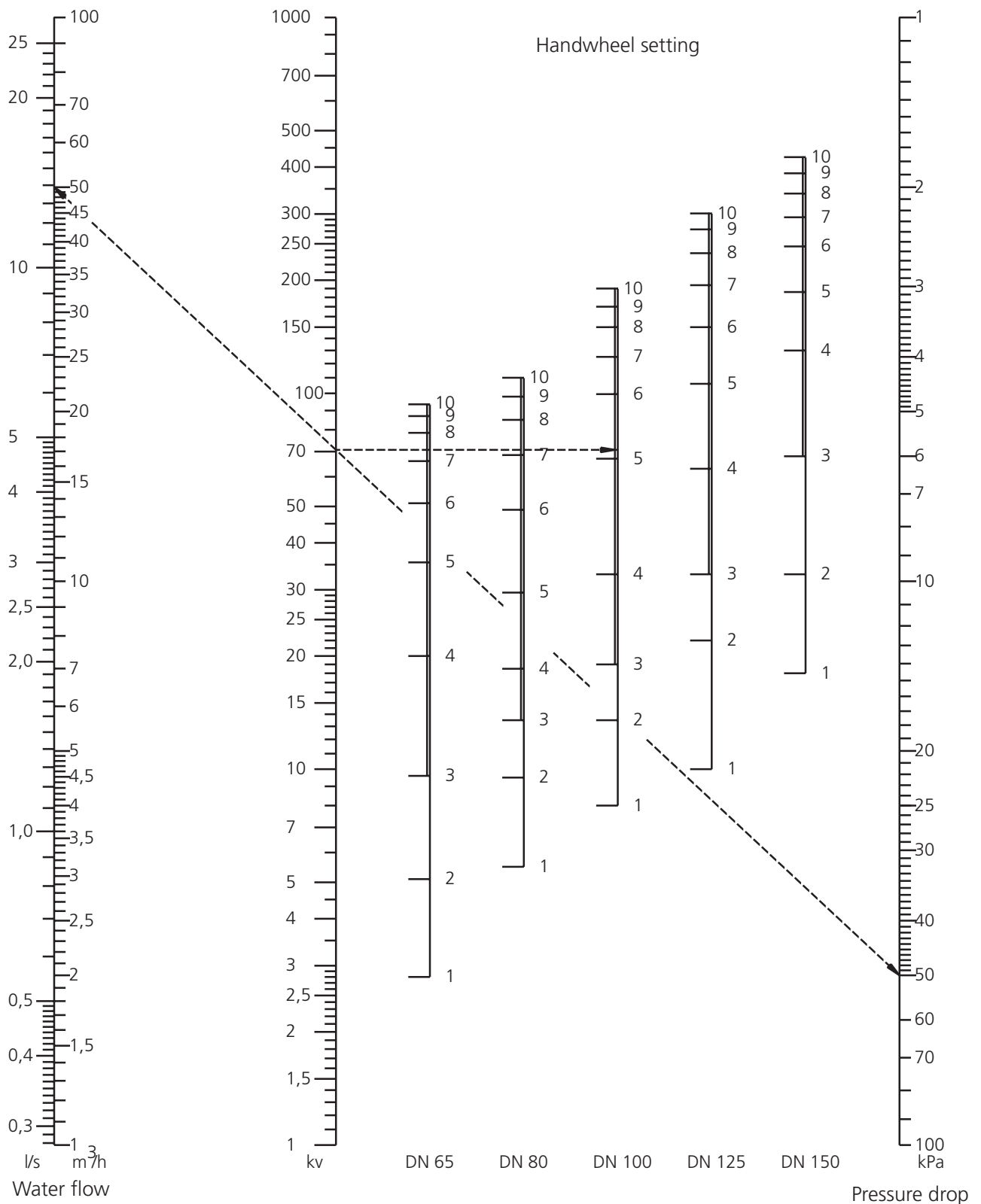

We recommend a pressure drop at 5-10 kPa at rated valve.